

10W isolated DC-DC converter in DIP package  
Ultra-wide input and regulated dual/single output



Patent Protection

CE Report EN62368-1   
 UKCA Report BS EN62368-1   
 CB IEC60950-1   
 RoHS

URA\_YMD-10WR3 & URB\_YMD-10WR3 series are isolated 10W DC-DC converter products feature an ultra-wide with 4:1 input voltage with efficiencies of up to 88%. 1500VDC input to output isolation, operating ambient temperature range of -40°C to +85°C, input under-voltage protection, output short-circuit, over-current, over-voltage protection. They meet CLASS A of CISPR32/EN55032 EMI standards without external components, optional packages are offered for chassis or DIN-rail mounting (A2S, A4S), adding additional input reverse polarity protection and they are widely used in applications such as industrial control, electric power, instruments, communication and railway applications.

### FEATURES

- Ultra-wide 4:1 input voltage range
- High efficiency up to 88%
- No-load power consumption as low as 0.12W
- I/O isolation test voltage 1.5k VDC
- Input under-voltage protection, output short-circuit, over-current, over-voltage protection
- Operating ambient temperature range: -40°C to +85°C
- Meets CISPR32/EN55032 CLASS A, without extra components
- Input reverse polarity protection available with Chassis (A2S) or 35mm DIN-Rail mounting (A4S) version
- Meets EN50155 railway standard
- Industry standard pin-out

### Selection Guide

Certification	Part No. ①	Input Voltage (VDC)		Output		Full Load Efficiency ④ (%) Min./Typ.	Capacitive Load ⑤ (μF) Max.
		Nominal ② (Range)	Max. ③	Voltage(VDC)	Current (mA) Max./Min.		
EN/BS EN/IEC	*URA2405YMD-10WR3	24 (9-36)	40	±5	±1000/0	81/83	1000
	URA2409YMD-10WR3			±9	±555/0	84/86	680
	*URA2412YMD-10WR3			±12	±416/0	85/87	470
	URA2415YMD-10WR3			±15	±333/0	85/87	330
	*URA2424YMD-10WR3			±24	±208/0	85/87	100
	URB2403YMD-10WR3			3.3	2400/0	75/77	2200
	URB2405YMD-10WR3			5	2000/0	80/82	2200
	URB2409YMD-10WR3			9	1111/0	83/85	680
	URB2412YMD-10WR3			12	833/0	84/86	470
	URB2415YMD-10WR3			15	667/0	84/86	330
	URB2424YMD-10WR3			24	416/0	86/88	100
	*URA4805YMD-10WR3			48 (18-75)	80	±5	±1000/0
	*URA4812YMD-10WR3	±12	±416/0			85/87	470
	*URA4815YMD-10WR3	±15	±333/0			85/87	330
	*URA4824YMD-10WR3	±24	±208/0			85/87	100
	*URB4803YMD-10WR3	3.3	2400/0			77/79	2200
	*URB4805YMD-10WR3	5	2000/0			81/83	2200
	*URB4812YMD-10WR3	12	833/0			85/87	470
	*URB4815YMD-10WR3	15	667/0			85/87	330
	*URB4824YMD-10WR3	24	416/0			86/88	100

Notes:

① Use "H" suffix for heat sink mounting, "A2S" suffix for chassis mounting and "A4S" suffix for DIN-Rail mounting;

② The A2S and A4S Model's start-up and minimum input voltages are increased by 1VDC due to the input reverse polarity protection circuit;

- ③ Exceeding the maximum input voltage may cause permanent damage;
- ④ Efficiency is measured at nominal input voltage and rated output load; efficiencies for A2S and A4S Model's is decreased by 2% due to the input reverse polarity protection circuit;
- ⑤ The specified maximum capacitive load value for positive and negative output is identical;
- ⑥ Products marked with "\*" need an input capacitor in order to meet conducted specifications of CISPR32/EN55032 CLASS A.

### Input Specifications

Item	Operating Conditions	Min.	Typ.	Max.	Unit	
Input Current (full load / no-load)	24VDC nominal input series, nominal input voltage	3.3VDC output	--	429/5	440/12	mA
		Others	--	502/5	521/12	
	48VDC nominal input series, nominal input voltage	3.3VDC output	--	190/4	215/8	
		Others	--	251/4	258/8	
Reflected Ripple Current	24VDC nominal input series, nominal input voltage	--	40	--		
	48VDC nominal input series, nominal input voltage	--	30	--		
Surge Voltage (1sec. max.)	24VDC nominal input series	-0.7	--	50	VDC	
	48VDC nominal input series	-0.7	--	100		
Start-up Voltage	24VDC nominal input series	--	--	9		
	48VDC nominal input series	--	--	18		
Input Under-voltage Protection	24VDC nominal input series	5.5	6.5	--	VDC	
	48VDC nominal input series	12	15.5	--		
Start-up Time	Nominal input voltage & constant resistance load	--	10	--	ms	
Input Filter		Pi filter				
Hot Plug		Unavailable				
Ctrl *	Module on	Ctrl pin open or pulled high (3.5-12VDC)				
	Module off	Ctrl pin pulled low to GND (0-1.2VDC)				
	Input current when off	--	6	10	mA	

Note: \*The Ctrl pin voltage is referenced to input GND.

### Output Specifications

Item	Operating Conditions	Min.	Typ.	Max.	Unit
Voltage Accuracy <sup>①</sup>	0%-100% load	--	±1	±3	%
Linear Regulation	Input voltage variation from low to high at full load	Vo1	±0.2	±0.5	
		Vo2	±0.5	±1	
Load Regulation <sup>②</sup>	5%-100% load	Vo1	±0.5	±1	
		Vo2	±0.5	±1.5	
Cross Regulation	Dual output, Vo1 load at 50%, Vo2 load at range of 10%-100%	--	--	±5	
Transient Recovery Time	25% load step change, nominal input voltage	--	300	500	μs
Transient Response Deviation		--	±3	±5	%
Temperature Coefficient	Full load	--	--	±0.03	%/°C
Ripple & Noise <sup>③</sup>	20MHz bandwidth, 5%-100% load	--	40	80	mVp-p
Over-voltage Protection	Input voltage range	110	--	160	%Vo
Over-current Protection		110	140	190	%Io
Short-circuit Protection		Continuous, self-recovery			

Note:

- ① Output voltage accuracy of ±5VDC/±9VDC output converter for 0%-5% load is ±5% max;
- ② Load regulation for 0%-100% load is ±5%;
- ③ Under 0% -5% load conditions, ripple & noise does not exceed 5%Vo. The "parallel cable" method is used for Ripple and Noise test, please refer to DC-DC Converter Application Notes for specific information.

### General Specifications

Item	Operating Conditions	Min.	Typ.	Max.	Unit
------	----------------------	------	------	------	------

Isolation	Input-output Electric Strength Test for 1 minute with a leakage current of 1mA max.	1500	--	--	VDC
Insulation Resistance	Input-output resistance at 500VDC	1000	--	--	MΩ
Isolation Capacitance	Input-output capacitance at 100kHz/0.1V	--	1000	--	pF
Operating Temperature	See Fig. 1	-40	--	+85	°C
Storage Temperature		-55	--	+125	
Storage Humidity	Non-condensing	5	--	95	%RH
Pin Soldering Resistance Temperature	Soldering spot is 1.5mm away from case for 10 seconds	--	--	+300	°C
Vibration		IEC/EN61373 - Category 1, Grade B			
Switching Frequency *	PWM mode	--	350	--	kHz
MTBF	MIL-HDBK-217F@25°C	1000	--	--	k hours

Note: \*Switching frequency is measured at full load. The module reduces the switching frequency for light load (below 50%) efficiency improvement.

### Mechanical Specifications

Case Material	Aluminum alloy				
Dimensions	Horizontal package (without heat sink)		25.40 x 25.40 x 11.70 mm		
	Horizontal package (with heat sink)		25.40 x 25.40 x 16.20 mm		
	A2S chassis mounting		76.00 x 31.50 x 21.20 mm		
	A4S DIN-rail mounting		76.00 x 31.50 x 25.80 mm		
Weight	without heat sink	Horizontal package/A2S chassis mounting/A4S DIN-Rail mounting		12.5g/36.0g/56.0g (Typ.)	
	with heat sink	Horizontal package		17g	
Cooling method	Free air convection				

### Electromagnetic Compatibility (EMC)

Emissions	CE	CISPR32/EN55032	CLASS A (Without extra components)/ CLASS B (see Fig.3-② for recommended circuit)		
	RE	CISPR32/EN55032	CLASS A (Without extra components)/ CLASS B (see Fig.3-② for recommended circuit)		
Immunity	ESD	IEC/EN61000-4-2	Contact ±4kV		perf. Criteria B
	RS	IEC/EN61000-4-3	10V/m		perf. Criteria A
	EFT	IEC/EN61000-4-4	±2kV (see Fig.3-① for recommended circuit)		perf. Criteria B
	Surge	IEC/EN61000-4-5	line to line ±2kV (see Fig.3-① for recommended circuit)		perf. Criteria B
	CS	IEC/EN61000-4-6	3 Vr.m.s		perf. Criteria A
	Voltage dips, short interruptions and voltage variations immunity	IEC/EN61000-4-29	0%, 70%		perf. Criteria B

### Electromagnetic Compatibility (EMC) (EN50155)

Emissions	CE	EN50121-3-2	150kHz-500kHz	99dBuV (see Fig.3-② for recommended circuit)	
		EN55016-2-1	500kHz-30MHz	93dBuV (see Fig.3-② for recommended circuit)	
	RE	EN50121-3-2	30MHz-230MHz	40dBuV/m at 10m (see Fig.3-② for recommended circuit)	
		EN55016-2-1	230MHz-1GHz	47dBuV/m at 10m (see Fig.3-② for recommended circuit)	
Immunity	ESD	EN50121-3-2	Contact ±6kV/Air ±8kV		perf. Criteria A
	RS	EN50121-3-2	20V/m		perf. Criteria A
	EFT	EN50121-3-2	±2kV 5/50ns	5kHz (see Fig.3-① for recommended circuit)	perf. Criteria A
	Surge	EN50121-3-2	line to line ±1kV (42Ω, 0.5μF) (see Fig.3-① for recommended circuit)		perf. Criteria A
	CS	EN50121-3-2	0.15MHz-80MHz	10V r.m.s	

### Typical Characteristic Curves

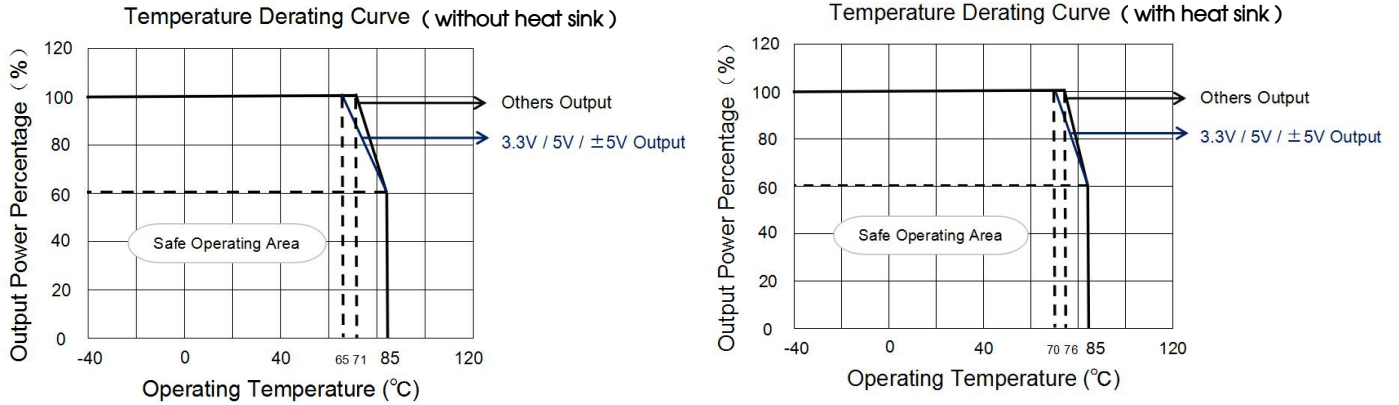
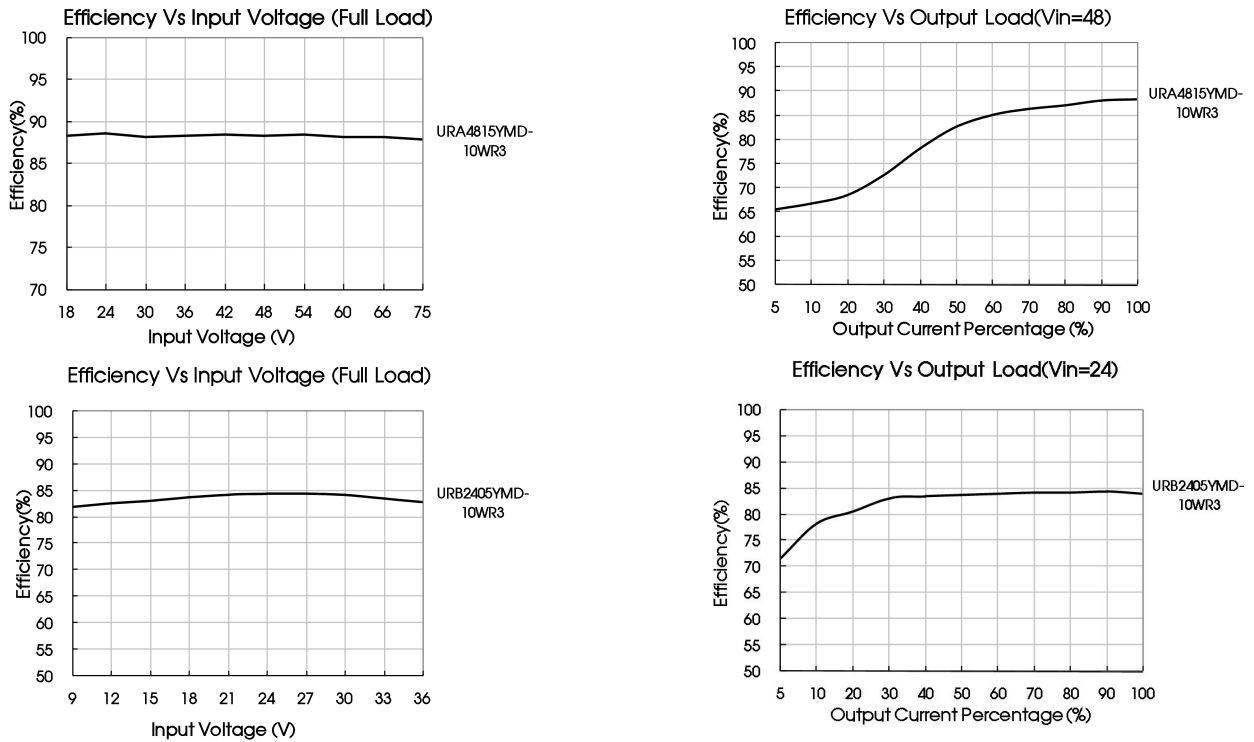

Fig. 1



Design Reference

1. Typical application

All the DC/DC converters of this series are tested before delivery using the recommended circuit shown in Fig. 2. Input and/or output ripple can be further reduced by appropriately increasing the input & output capacitor values  $C_{in}$  and  $C_{out}$  and/or by selecting capacitors with a low ESR (equivalent series resistance). Also make sure that the capacitance is not exceeding the specified max. capacitive load value of the product.

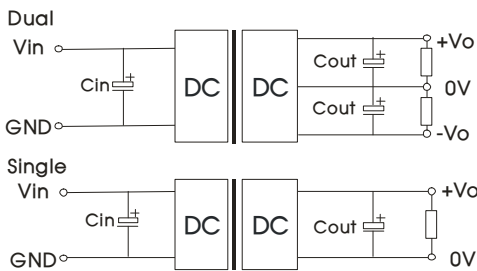

Fig. 2

Vin(VDC)	Vout(VDC)	Cin	Cout
24	3.3/5/±5	100µF/50V	10µF/16V
	9/12/15/±9/±12/±15		10µF/25V
	24/±24		10µF/50V
48	3.3/5/±5	10µF - 47µF/100V	10µF/16V
	9/12/15/±9/±12/±15		10µF/25V
	24/±24		10µF/50V

2. EMC compliance circuit

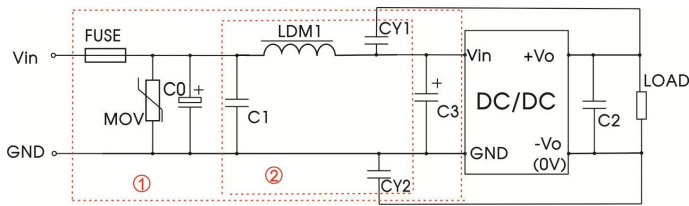

Fig. 3

Notes: For EMC tests we use Part ① in Fig. 3 for immunity and part ② for emissions test. Selecting based on needs.

Parameter description:

Model	Vin: 24VDC	Vin: 48VDC
FUSE	Choose according to actual input current	
MOV	S20K30	S14K60
C0, C3	330μF/50V	330μF/100V
C1	1μF/50V	1μF/100V
C2	Refer to the Cout in Fig.2	
LDM1	4.7μH	
CY1, CY2	1nF/2kV	

- The products do not support parallel connection of their output
- For additional information please refer to DC-DC converter application notes on [www.mornsun-power.com](http://www.mornsun-power.com)

### Horizontal Package (without heat sink) Dimensions and Recommended Layout

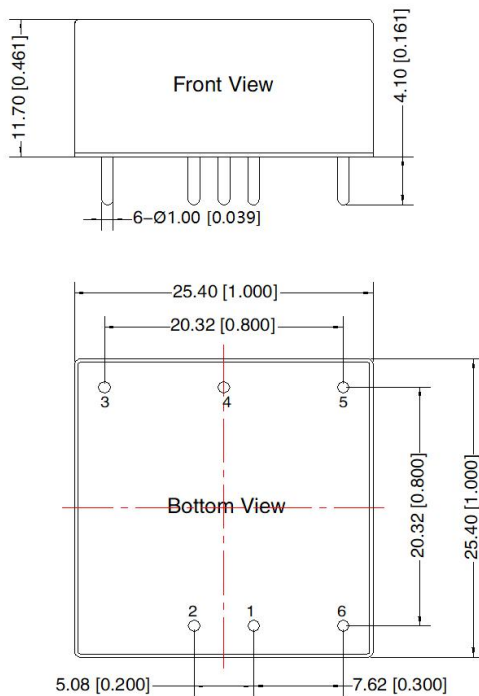

Note:  
Unit: mm[inch]  
PIN1/2/3/4/5/6:  $\phi$  1.0mm  
Pin diameter tolerances:  $\pm 0.10$  [  $\pm 0.004$  ]  
General tolerances:  $\pm 0.50$  [  $\pm 0.020$  ]

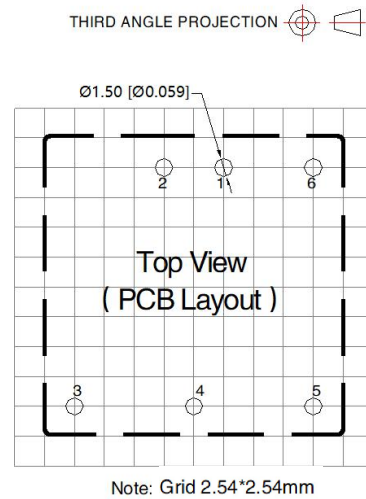

Pin	Pin-Out	
	Single	Dual
1	GND	GND
2	Vin	Vin
3	+Vo	+Vo
4	No Pin	0V
5	0V	-Vo
6	Ctrl	Ctrl

### Horizontal Package (with heat sink) Dimensions and Recommended Layout



THIRD ANGLE PROJECTION 

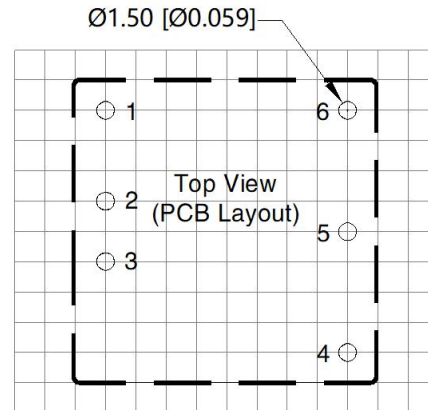
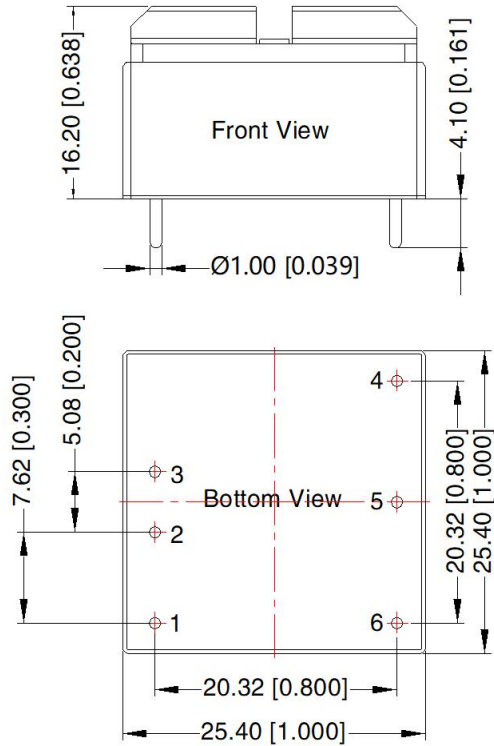

Note: Grid 2.54\*2.54mm

Pin-Out		
Pin	Single	Double
1	Ctrl	Ctrl
2	GND	GND
3	Vin	Vin
4	+Vo	+Vo
5	No Pin	0V
6	0V	-Vo

Note:  
Unit: mm[inch]  
Pin diameter tolerances:  $\pm 0.10$  [ $\pm 0.004$ ]  
General tolerances:  $\pm 0.50$  [ $\pm 0.020$ ]

URA\_YMD-10WR3A2S & URB\_YMD-10WR3A2S Dimensions

THIRD ANGLE PROJECTION 

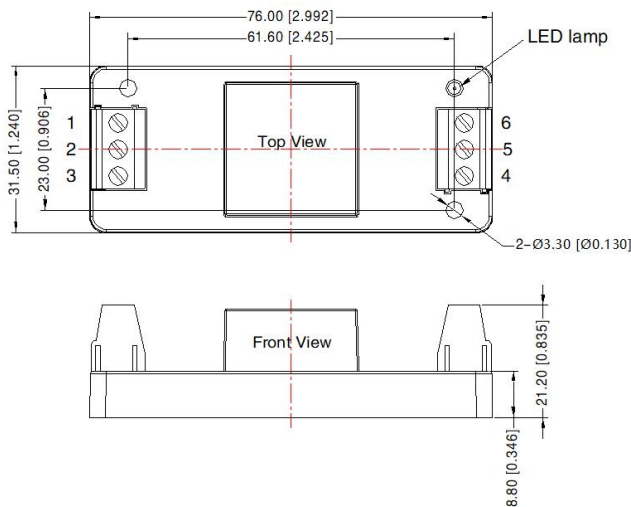

Pin-Out						
Pin	1	2	3	4	5	6
Single	Ctrl	GND	Vin	+Vo	NC	0V
Dual	Ctrl	GND	Vin	+Vo	0V	-Vo

Note:  
Unit: mm[inch]  
Wire range: 24-12 AWG  
Tightening torque: Max 0.4 N · m  
General tolerances:  $\pm 1.00$  [ $\pm 0.039$ ]

URA\_YMD-10WR3A4S & URB\_YMD-10WR3A4S Dimensions

THIRD ANGLE PROJECTION 

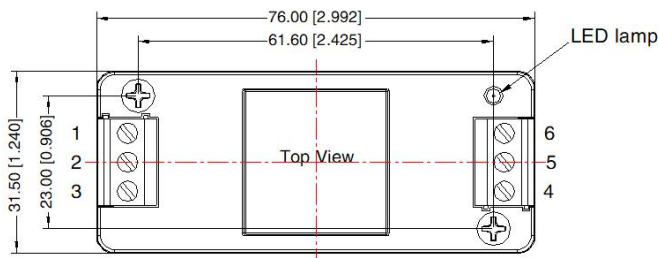

Pin-Out						
Pin	1	2	3	4	5	6
Single	Ctrl	GND	Vin	+Vo	NC	0V
Dual	Ctrl	GND	Vin	+Vo	0V	-Vo

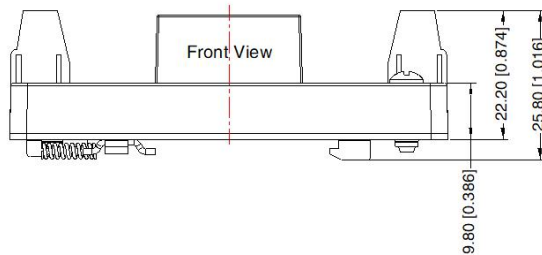

Note:  
Unit: mm[inch]  
Mounting rail: TS35  
Wire range: 24-12 AWG  
Tightening torque: Max 0.4 N · m  
General tolerances:  $\pm 1.00$  [ $\pm 0.039$ ]

Note:

1. For additional information on Product Packaging please refer to [www.mornsun-power.com](http://www.mornsun-power.com). Packaging bag number: 58210003 (DIP), 58220022(A2S/A4S package);
2. The maximum capacitive load offered were tested at input voltage range and full load;
3. Unless otherwise specified, parameters in this datasheet were measured under the conditions of  $T_a=25^\circ\text{C}$ , humidity<75%RH with nominal input voltage and rated output load;
4. All index testing methods in this datasheet are based on our company corporate standards;
5. We can provide product customization service, please contact our technicians directly for specific information;
6. Products are related to laws and regulations: see "Features" and "EMC";
7. Our products shall be classified according to ISO14001 and related environmental laws and regulations, and shall be handled by qualified units.

Mornsun Guangzhou Science & Technology Co., Ltd.

Address: No. 8, Nanyun 4th Road, Huangpu District, Guangzhou, China  
Tel: 86-20-38601850 Fax: 86-20-38601272

E-mail: [info@mornsun.cn](mailto:info@mornsun.cn)

[www.mornsun-power.com](http://www.mornsun-power.com)