



STEVAL-SPBT3ATV3

USB dongle for the Bluetooth® class 2 SPBT2632C2A.AT2 module

Data brief

Features

- Based on a V3.0 Bluetooth® class 2 module SPBT2632C2A.AT2
- USB interface and power supply
- Supports reprogrammability via USB interface
- Reset button
- Antenna onboard
- RoHS compliant

Description

The STEVAL-SPBT3ATV3 demonstration board is a design tool to evaluate the SPBT2632C2A.AT2 module in a quick and simple way.

The dongle includes the RF antenna and the USB connector.

The USB connector is used to connect the dongle to a PC, to access the Bluetooth® module, and to supply the dongle.

The STEVAL-SPBT3ATV3 includes downloaded FW, enabling the user to create a Bluetooth® link with simple AT commands. The AT command list is detailed in the User Manual UM1547.

The AN4127 application note describes how to get started with the STEVAL-SPBT3ATV3.

The SPBT2632C2A.AT2-based dongle is a demonstration tool only, to be used strictly for evaluation purposes. It is not a product in itself.

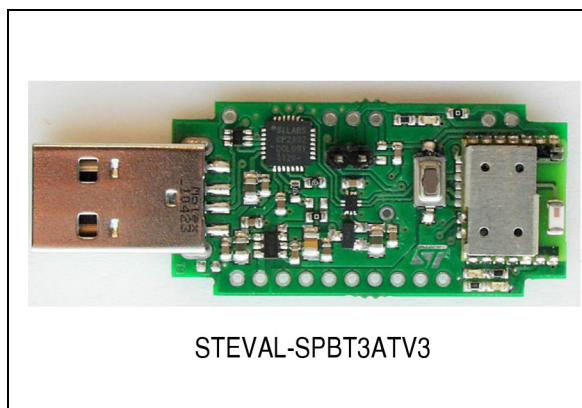

Contents

1	Recommended operating conditions	3
2	Dongle layout	4
3	I/O connections	5
	3.1 PAD description	5
4	Dongle schematic	6
5	Revision history	7

1 Recommended operating conditions

Table 1. Recommended operating conditions

Symbol	Parameter	Conditions	Min.	Typ.	Max.	Unit
V _{DD}	Board supply voltage	-40 °C < T < 85 °C	4.5	5	5.5	V
Top	Operating case temperature range		-40		+85	°C

2 Dongle layout

Figure 1. Dongle component layout, front side

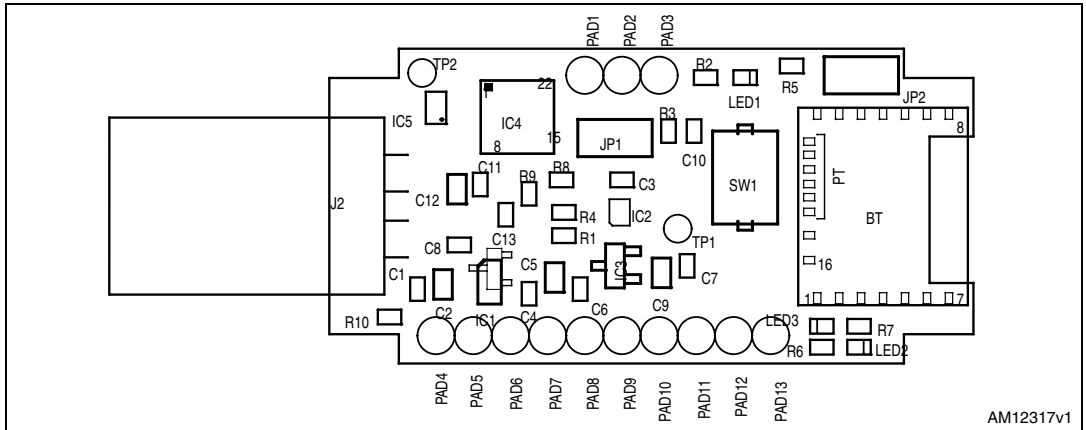
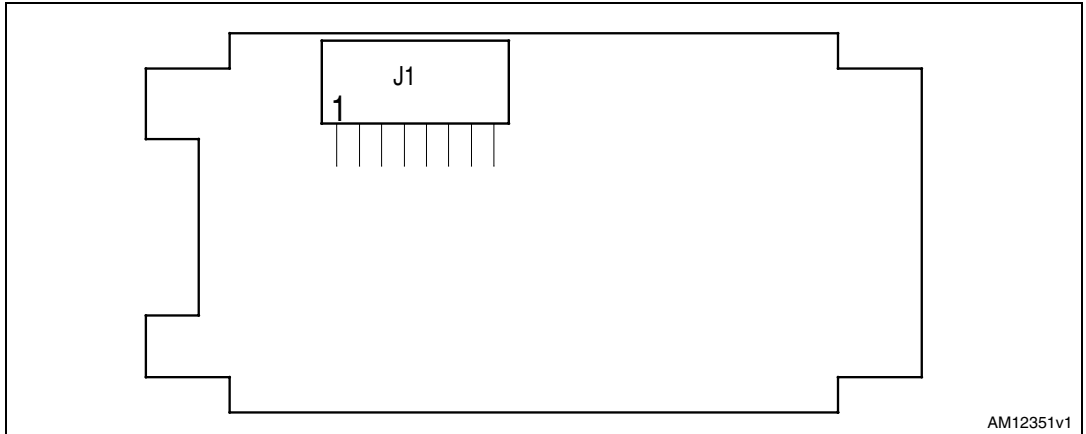

Figure 2. Dongle component layout, bottom side



3 I/O connections

3.1 PAD description

Other than the USB plug, some pads are also available. In fact, pads PAD1 to PAD13 make the SPBT2632C2A.AT2 pins available to the user.

Figure 3. Available pads

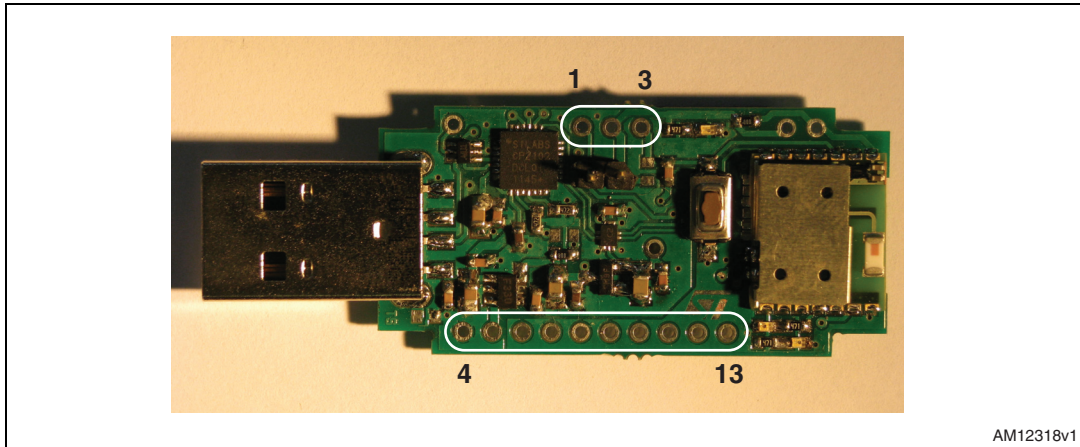

AM12318v1

Table 2 gives a description of these pads.

Table 2. Pad connections

		Description
(PAD)	1	BOOT0 - Boot pin used for firmware downloading - used for testing purposes
	2	3.3 V (module – LED1 is connected to this PAD)
	3	RESETN - reset - connected in parallel to onboard reset switch
	4	GND
	5	+5 V (USB)
	6	LPO (external 32.768 kHz frequency input to allow deep sleep and sniff mode Bluetooth module functional states)
	7	GPIO07 – general purpose I/O
	8	GPIO01 – general purpose I/O (see note) (LED2 is connected to this GPIO)
	9	GPIO02 – general purpose I/O (see note)
	10	GPIO03 – general purpose I/O (see note)
	11	GPIO04 – general purpose I/O (see note) (LED3 is connected to this GPIO)
	12	GPIO06 – general purpose I/O see note)
	13	GPIO05 – general purpose I/O

Note: Default configuration - different configurations can be chosen (see datasheet).

4 Dongle schematic

Figure 4. Dongle electrical drawing

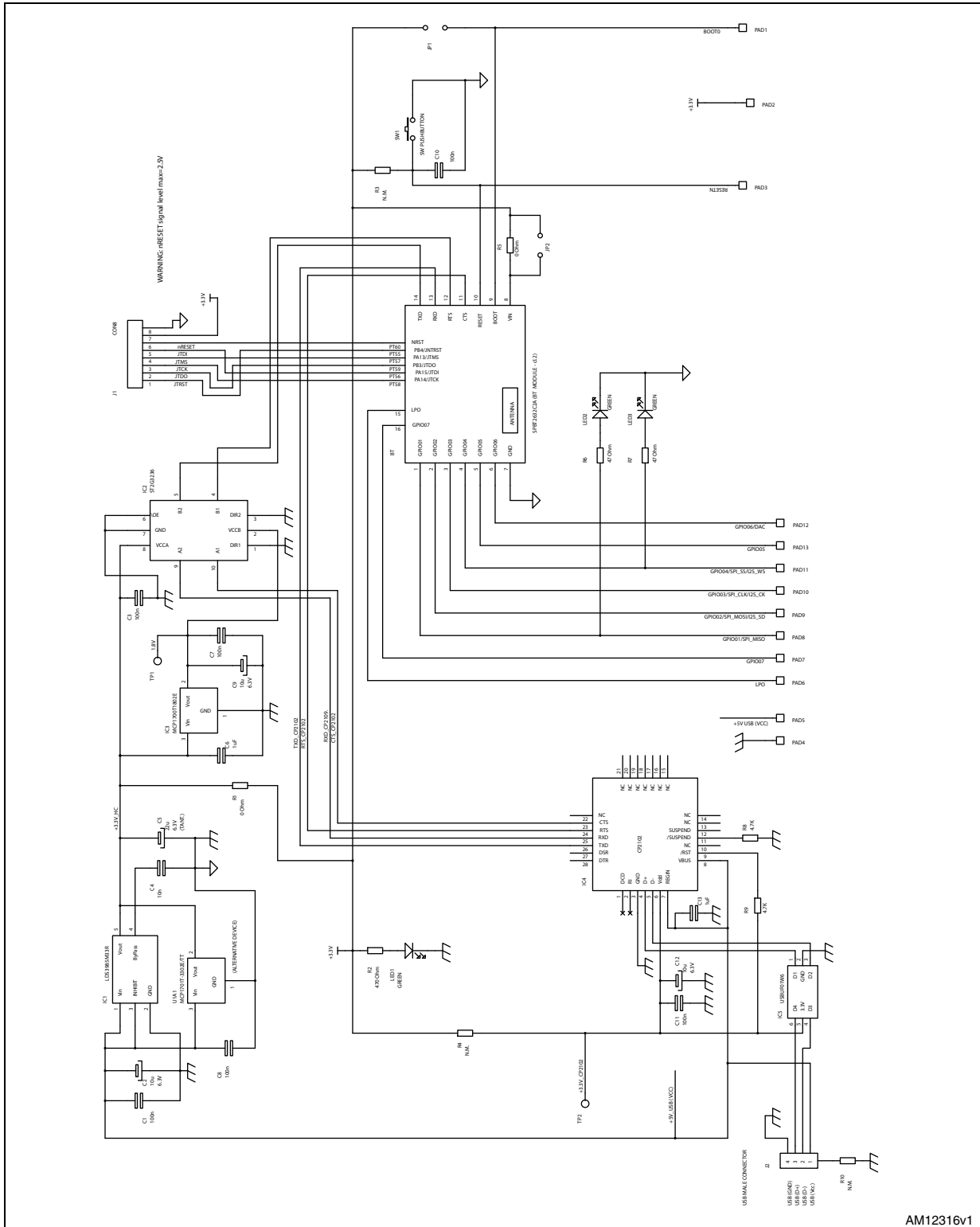

5 Revision history

Table 3. Document revision history

Date	Revision	Changes
12-Jun-2012	1	Initial release.
25-Jun-2012	2	Modified: photo in the cover page, description, Figure 1 and 4

Please Read Carefully:

Information in this document is provided solely in connection with ST products. STMicroelectronics NV and its subsidiaries ("ST") reserve the right to make changes, corrections, modifications or improvements, to this document, and the products and services described herein at any time, without notice.

All ST products are sold pursuant to ST's terms and conditions of sale.

Purchasers are solely responsible for the choice, selection and use of the ST products and services described herein, and ST assumes no liability whatsoever relating to the choice, selection or use of the ST products and services described herein.

No license, express or implied, by estoppel or otherwise, to any intellectual property rights is granted under this document. If any part of this document refers to any third party products or services it shall not be deemed a license grant by ST for the use of such third party products or services, or any intellectual property contained therein or considered as a warranty covering the use in any manner whatsoever of such third party products or services or any intellectual property contained therein.

UNLESS OTHERWISE SET FORTH IN ST'S TERMS AND CONDITIONS OF SALE ST DISCLAIMS ANY EXPRESS OR IMPLIED WARRANTY WITH RESPECT TO THE USE AND/OR SALE OF ST PRODUCTS INCLUDING WITHOUT LIMITATION IMPLIED WARRANTIES OF MERCHANTABILITY, FITNESS FOR A PARTICULAR PURPOSE (AND THEIR EQUIVALENTS UNDER THE LAWS OF ANY JURISDICTION), OR INFRINGEMENT OF ANY PATENT, COPYRIGHT OR OTHER INTELLECTUAL PROPERTY RIGHT.

UNLESS EXPRESSLY APPROVED IN WRITING BY TWO AUTHORIZED ST REPRESENTATIVES, ST PRODUCTS ARE NOT RECOMMENDED, AUTHORIZED OR WARRANTED FOR USE IN MILITARY, AIR CRAFT, SPACE, LIFE SAVING, OR LIFE SUSTAINING APPLICATIONS, NOR IN PRODUCTS OR SYSTEMS WHERE FAILURE OR MALFUNCTION MAY RESULT IN PERSONAL INJURY, DEATH, OR SEVERE PROPERTY OR ENVIRONMENTAL DAMAGE. ST PRODUCTS WHICH ARE NOT SPECIFIED AS "AUTOMOTIVE GRADE" MAY ONLY BE USED IN AUTOMOTIVE APPLICATIONS AT USER'S OWN RISK.

Resale of ST products with provisions different from the statements and/or technical features set forth in this document shall immediately void any warranty granted by ST for the ST product or service described herein and shall not create or extend in any manner whatsoever, any liability of ST.

ST and the ST logo are trademarks or registered trademarks of ST in various countries.

Information in this document supersedes and replaces all information previously supplied.

The ST logo is a registered trademark of STMicroelectronics. All other names are the property of their respective owners.

© 2012 STMicroelectronics - All rights reserved

STMicroelectronics group of companies

Australia - Belgium - Brazil - Canada - China - Czech Republic - Finland - France - Germany - Hong Kong - India - Israel - Italy - Japan - Malaysia - Malta - Morocco - Philippines - Singapore - Spain - Sweden - Switzerland - United Kingdom - United States of America

www.st.com